

LOW
EMISSIONS

9.9 MMBTU
INPUT



250 HP

PORTABLE BOILER ROOM™



**DUAL-FUEL
HIGH PRESSURE
WATER TREATMENT
FUEL HANDLING
FUEL STORAGE**

COMPLETELY PIPED
WIRED & READY-TO-GO



Please contact Powerhouse today
for pricing and availability

1.800.37.STEAM
www.powerhouse.com
rentals@powerhouse.com



POWERHOUSE
EQUIPMENT & ENGINEERING
CO INC



250 HP
PORTABLE
BOILER ROOM

CAPACITY

STEAM

8,625 250
 LBS/HR PSIG

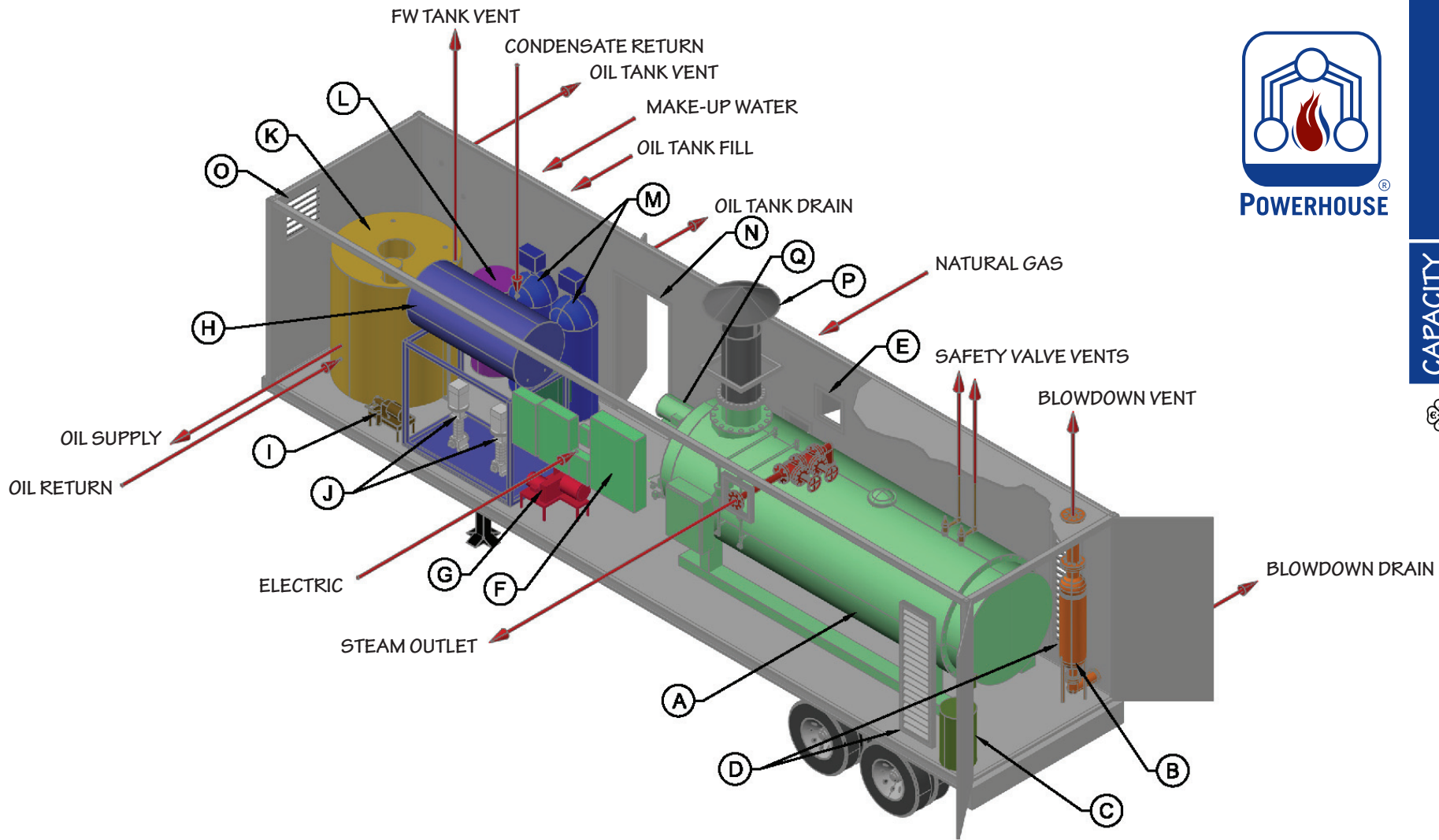

MAJOR COMPONENTS

- | | |
|-------------------------|----------------------------|
| A CLEAVER BROOKS BOILER | I OIL PUMP |
| B BLOWDOWN TANK | J FEEDWATER PUMPS |
| C CHEMICAL TANK & PUMP | K 1,000 GAL FUEL OIL TANK |
| D LOUVRE | L BRINE TANK W/ FOOT VALVE |
| E HANDHOLE ACCESS | M S/S WATER SOFTENERS |
| F ELECTRICAL PANELS | N MAN DOOR |
| G AIR COMPRESSOR | O MOTORIZED EXHAUST FAN |
| H S/S FEEDWATER TANK | |

REQUIREMENTS

CITY WATER: 31 GPM @ 50 PSI
 FUEL INPUT: 9,900,000 BTU/HR
 NATURAL GAS: 9,900 CFH (1,000 BTU/CU.FT.)
 MIN: 3 PSI / MAX: 7 PSI
 #2 FUEL OIL: 73 GPH (140,000 BTU/GAL)
 ELECTRIC 90 AMPS @ 460V/3PH/60HZ
 ATOMIZING AIR: AIR COMPRESSOR INCLUDED
 INSTRUMENT AIR: NOT REQUIRED

PHYSICAL

ENCLOSURE: STEEL CONTAINER W/
 REMOVABLE CHASSIS
 LENGTH: 40' 0"
 WIDTH: 8' 0"
 HEIGHT: 9' 6" WITHOUT CHASSIS
 13' 6" WITH CHASSIS

- ADDITIONAL ITEMS**
- GAS TRAIN
 - LPG PILOT TANK
 - UNIT HEATER
 - STUB STACK
 - STEAM VALVES