

COMPLETE
HW SYSTEM



250 GPM

PORTABLE BOILER ROOM™



**HOT WATER
NATURAL GAS
CIRCULATING PUMPS
HEAT EXCHANGER
HIGH EFFICIENCY**

COMPLETELY PIPED
WIRED & READY-TO-GO



Please contact Powerhouse today
for pricing and availability

1.800.37.STEAM
www.powerhouse.com
rentals@powerhouse.com





250 GPM
125 HP
**PORTABLE
BOILER ROOM**

CAPACITY

HOT WATER	
250 GPM	50 PSIG
30 °F TEMP RISE	

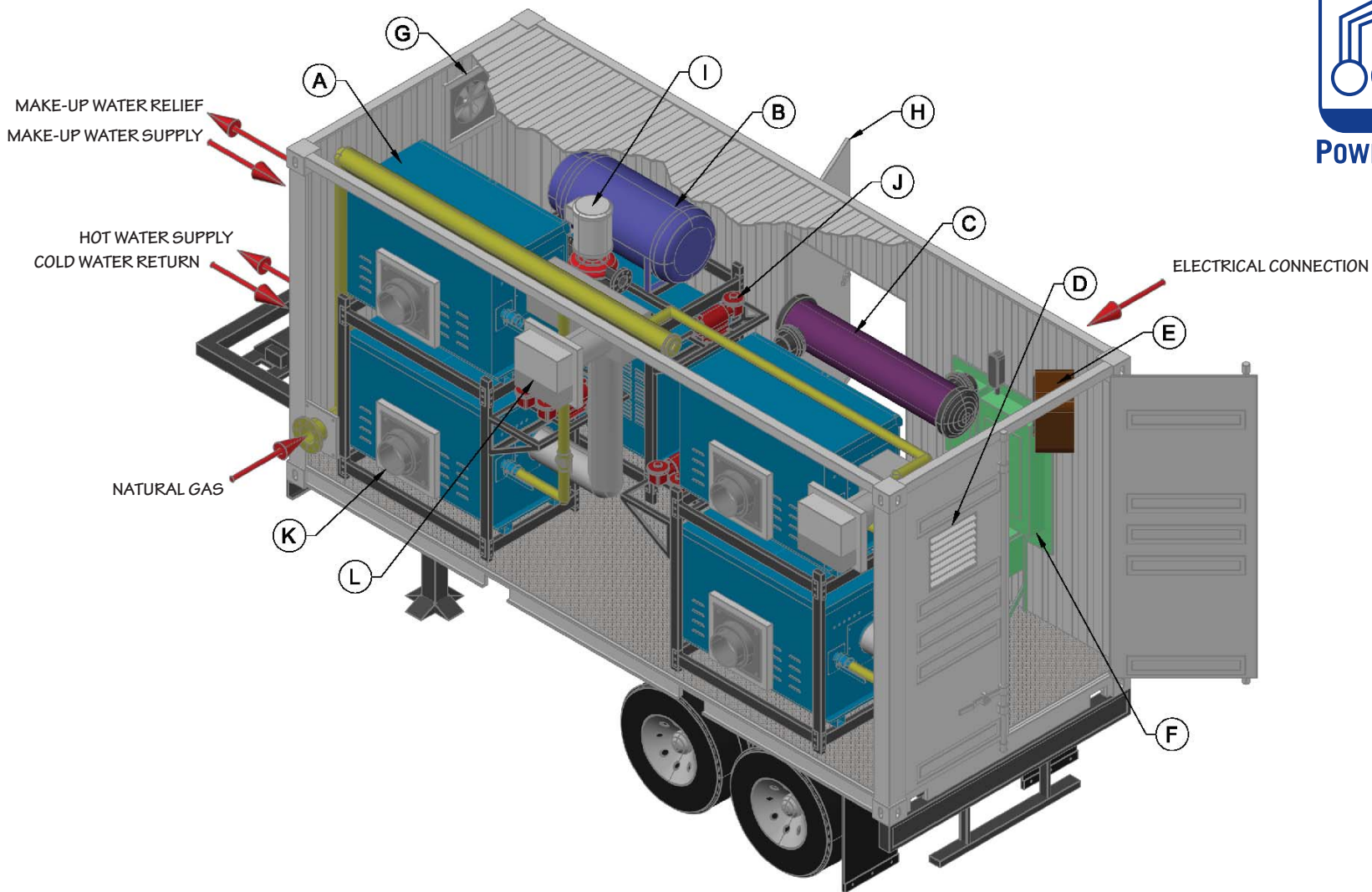

MAJOR COMPONENTS

- | | | | |
|---|---------------------------|---|---------------------------|
| A | TELEDYNE-LARS BOILER (5) | J | BOILER RECIRCULATING PUMP |
| B | EXPIATION TANK | K | EXHAUST OUTLET |
| C | HEAT EXCHANGER | L | AIR INTAKE |
| D | LOUVRE | | |
| E | UNIT HEATER | | |
| F | ELECTRICAL PANEL | | |
| G | EXHAUST FAN | | |
| H | MAN DOOR | | |
| I | SYSTEM RECIRCULATING PUMP | | |

REQUIREMENTS

CITY WATER:	250 GPM @ 50 PSI
FUEL INPUT:	5,000,000 BTU/HR
NATURAL GAS:	5,000 CFH (1,000 BTU/CU.FT.)
	MIN: 8" WC / MAX: 1 PSI
#2 FUEL OIL:	N/A
ELECTRIC	60 AMPS @ 460V/3PH/60HZ
ATOMIZING AIR:	NOT REQUIRED
INSTRUMENT AIR:	NOT REQUIRED

PHYSICAL

ENCLOSURE:	STEEL CONTAINER W/ REMOVABLE CHASSIS
LENGTH:	20' 0" WITHOUT CHASSIS 23' 8" WITH CHASSIS
WIDTH:	8' 0"
HEIGHT:	9' 6" WITHOUT CHASSIS 13' 6" WITH CHASSIS